

# Psychometric Properties of the TEA Personality Test

## Evidence of Reliability and Construct Validity

David Arribas-Águila

Research and Development Department, TEA Ediciones, Madrid, Spain

**Abstract.** The present study examined the psychometric properties of the TEA Personality Test (TPT) in a sample of 23,062 Spanish adults. The TPT is a self-report questionnaire to be answered using a four-point Likert scale to assess personality at work and it is the third most frequently used tool by work psychologists in Spain. The reliability and validity analyses indicated that the TPT has adequate psychometric properties for the Spanish sample analyzed. Ordinal  $\alpha$  was used to calculate the internal consistency reliability of the scales. Results were higher than those of Cronbach's  $\alpha$  reported in the TPT's technical manual ( $p < .001$ ). Results from confirmatory factor analyses showed an acceptable goodness-of-fit for the theoretical three factors of the TPT's work personality model reported in the technical manual. The findings support the reliability and construct validity of the TPT.

**Keywords:** TPT, TEA personality test, reliability, construct validity

### Introduction

In recent years, there has been a growing tendency in the literature to examine the psychometric properties of psychological tests, such being the topic of many research studies (v.g., Lenzenweger, Clarkin, Kernberg, & Foelsch, 2001; Tsaousis & Georgiades, 2009; Tsaousis & Kepelis, 2004). Spanish adaptations of tests have also emerged (v.g., Alonso-Arbiol, Balluerka, Shaver, & Gillath, 2008; Buela-Casal, Carretero-Dios, De los Santos-Roig, & Bermúdez, 2003; García, Aluja, & García, 2004; Gomà-i-Freixanet, Valero, Puntí, & Zuckerman, 2004; Méndez, Hidalgo, & Inglés, 2002; Penley, Wiebe, & Nwosu, 2003; Rintala et al., 2002; Rodríguez Fornells, Lorenzo-Seva, & Andrés-Pueyo, 2001; Ruipérez, Ibáñez, Lorente, Moro, & Ortet, 2001). These studies provide relevant scientific evidence to update psychometric data and validity of tests over the years.

In most cases, the tests' technical manuals provide the most relevant information for their use and interpretation. However, authors and test developers emphasize the need to continue updating the psychometric properties and extending the research on which the test was based during its development and standardization (Arribas, Corral, & Pereña, 2010; Fernandez-Seara, Seisdedos, & Mielgo, 2008; Seisdedos, 2002a, 2002b, 2004a, 2004b, 2008). A systematic review of psychological tests and their properties is more widespread in the US than in Europe, and includes regular publications with the sole purpose of reviewing published tests (Geisinger, Spies, Carlson, & Plake, 2007).

Recently Muñiz and Fernandez-Hermida (2010) conducted a study on the most frequently used tests in Spain, using a questionnaire developed by the European Federation of Psychologists' Associations (EFPA). Personality questionnaires most frequently used by work psychologists were, in this order: 16PF-5 (Cattell, Cattell, & Cattell, 2005), PAPI (Kostick, 1976), TPT (Corral, Pereña, Pamos, & Seisdedos, 2002), IPV (ECPA, 2005), MMPI-2 (Hathaway & McKinley, 2002), BFQ (Caprara, Barbaranelli, & Borgogni, 2005), MCMI-III (Millon, 2007) and NEO PI-R (Costa & McCrae, 2008). It also highlights SOSIA (Gordon, ECPA, & TEA Ediciones, 2008), BIP (Hossiep & Paschen, 2008) and *compeTEA* (Arribas & Pereña, 2009).

The TEA Personality Test (TPT), as the third most frequently used personality questionnaire by work psychologists in Spain, has no more psychometric studies than those reported in the original edition and the third revised edition. The technical manual reports the test's reliability in terms of Cronbach's  $\alpha$ , with values ranging from 0.50 to 0.78 (median = 0.62). Construct validity was studied using an exploratory factor analysis (EFA), and its results suggest 3 second-order factors: Emotional Stability, Mental Openness, and Responsibility. There is no more information about reliability, construct validity, factorial solution fitness, or confirmatory theoretical structure in the manual.

Since the development of the TPT, the study of psychometric properties according to classical test theory has been significantly improved. In the field of reliability, Cron-

bach's (1951)  $\alpha$  coefficient is the norm-referenced technique that many researchers have been using to measure the internal consistency of tests (Cortina, 1993; Zumbo & Rupp, 2004). However, Cronbach's  $\alpha$  is based on the assumption of continuity of the variables and this assumption is not met by ordinal response items or Likert scales (Elo-súa & Zumbo, 2008). Several studies provide evidence that Cronbach's  $\alpha$  tends to underestimate the true reliability of test scores (Drewes, 2000; Nunnally & Bernstein, 1994; Osburn, 2000; Ten Berge & Hofstee, 1999) and shows a spurious decrease in its value when the number of categories in the rating scale is less than five (Lozano, García-Cueto, & Muñiz, 2008; Weng, 2004). An alternative procedure to Cronbach's  $\alpha$  coefficient is ordinal  $\alpha$ , based on the factor analysis of the polychoric correlation matrix (McDonald, 1999; Rupp, Koh, & Zumbo, 2003).

Construct validity has been traditionally explored using EFA, a statistical technique used to explore the possible underlying factor structure without imposing a preconceived structure on the outcome (Child, 1990). This technique is appropriate during test development, but confirmatory factor analysis (CFA) is a more powerful alternative that allows the researcher to postulate the relationship pattern a priori, using the knowledge of the theory or empirical research, and test the hypothesis statistically (Jöreskog, 1993).

The present research is aimed at providing updated evidence on the psychometric properties of the TPT in terms of reliability and construct validity. Reliability of the scales is explored using the ordinal approach, reliability of the dimensions is studied using the continuous factorial approach, and construct validity by means of CFA. We expected to replicate and to find better results with regards to reliability and construct validity than those reported in the technical manual. A satisfactory goodness-of-fit of the work personality model assessed by the TPT was also expected.

## Materials and Method

### Sample

Computerized archival data from the Internet Scoring System of TEA Ediciones ([www.e-perfil.com](http://www.e-perfil.com)) was used for this study. The TPT items and raw scores data were collected from 23,062 subjects with ages ranging from 18 to 75 (Mean = 30.10;  $SD = 7.62$ ), assessed in Spain between 2005 and 2010. In the sample, 41.1% were female ( $n = 9,476$ ) and 58.9% were male ( $n = 13,586$ ).

### Instrument

The TPT (Corral et al., 2002) is a 160-item self-report questionnaire to be answered using a 4-point Likert scale. According to the technical manual, TPT offers three main factor scores or dimensions (EE, Emotional Stability; AM,

Mental Openness; and RP, Responsibility) and 15 facets of personality in the workplace: maladjustment (DAJ), anxiety (ANS), depression (DEP), stress tolerance (EST), self-concept (ACO), tolerance & flexibility (TOL), adaptation to changes (ADA), interest in other cultures (CUL), availability (DIS), social intelligence (ISO), social integration (INS), teamwork (EQUI), professional self-demanding (PRO), dynamism & activity (DIN), and tenacity & constancy (TES). It also includes a validity scale to assess sincerity (SIN). The TPT norms are based on a representative sample of 15,509 adults in the work context (23.3% males and 76.6% females).

### Data Analysis

Polychoric matrix correlations of each scale and factor loadings of each item were obtained with MPLUS 5.2 software. Ordinal  $\alpha$ s were then calculated applying McDonald's formula (1999, p. 217):

$$\alpha = \frac{n}{n-1} \left[ \frac{n(\bar{\lambda})^2 - \bar{\lambda}^2}{n(\bar{\lambda})^2 + (u^2)} \right] \quad (1)$$

where

$\bar{\lambda}$  is the arithmetical mean of factor loadings,

$\bar{\lambda}^2$  is the arithmetical mean of the squared factor loadings, and

$u^2$  is the arithmetical mean of the variable uniqueness.

Pearson matrix correlations of each second-order dimension and factor loadings of each scale were also obtained with MPLUS 5.2 software. Continuous factorial  $\alpha$  of dimensions were also calculated by means of Equation 1.

Differences between reliability coefficients were estimated with Feldt's equality test with two independent samples (Feldt, 1980).

CFA with maximum likelihood (ML) estimation and fit statistics were done with AMOS 16.0. Two models were examined: (1) One single-factor control model with one first-order latent variable based on scales' composites; and (2) One model with three correlated factors, with three first-order latent variables based on scales' composites (related to the number of factors and scales loadings of the work personality model reported in the TPT technical manual).

### Procedure

Data were obtained from the e-perfil system ([www.e-perfil.com](http://www.e-perfil.com)), a web scoring platform that collects and stores all the TPT administrations in Spain. Examiners use the paper and pencil version of the test and manually enter item responses into the system to obtain raw scores, standard scores, and the scoring profile. Data are stored and exported into Excel format and include administration date, gender, age, item responses, raw scores, and standard scores.

**Table 1.** Factor loadings for TPT scales: polychoric EFA, RMSR, ordinal  $\alpha$ , and TPT's technical manual Cronbach's  $\alpha$ 

Item	DAJ	ANS	DEP	EST	ACO	TOL	ADA	CUL	ISO	INS	DIS	EQU	PRO	DIN	TES	SIN
1	.32	.35	.55	.42	.63	.45	.42	.26	.51	.31	.28	.26	.63	.48	.16	-.01
2	.65	.40	.30	.69	.43	.44	.36	.59	.60	.41	-.23	.33	.31	.35	.16	.22
3	.15	.12	.48	-.25	.23	.53	.02	.67	.21	.13	.68	.62	.54	.59	.64	.65
4	.25	.63	.33	.54	.63	.18	.64	.82	.48	.71	-.02	.31	.68	.41	.54	.11
5	.43	.61	.53	.46	.78	.36	.13	.31	-.06	.50	.42	.60	.37	-.04	.66	.12
6	.55	.64	.63	.24	.23	.51	.27	.49	.51	.34	.45	.42	.36	.47	.51	.55
7	.42	.60	.38	.44	.28	.38	-.06	.63	.62	.38	.67	.38	.69	.47	.41	.37
8	.57	.63	.64	.61	.63	.25	.13	.42	.64	.28	.39	.69	.59	.28	.68	.52
9	.27	.43	.60	.65	.17	.53	.76	.72	.59	.18	.33	.33	.67	-.07	.29	.17
10	.73	.15	.29	.64	.42	.09	.01	.41	.48	.56	.34	.33	.59	.29	.26	.31
Mean	.43	.45	.47	.44	.44	.37	.27	.53	.46	.38	.33	.43	.54	.32	.43	.30
RMSR	.050	.039	.081	.049	.087	.056	.115	.051	.088	.058	.064	.067	.053	.069	.086	.083
Ordinal $\alpha$	.77	.77	.73	.72	.75	.64	.63	.86	.77	.73	.65	.76	.79	.58	.76	.55
Technical manual Cronbach's $\alpha$	.50	.62	.55	.64	.65	.61	.61	.78	.52	.69	.62	.62	.70	.49	.64	.51

## Results

### Consistency Analysis

Factor loadings for the 16 polychoric EFA (15 personality scales and 1 Sincerity scale), root mean square residuals (RMSR) and ordinal  $\alpha$  values of the 10 items of the TPT scales are presented in Table 1; corresponding Cronbach's  $\alpha$ s reported in the TPT technical manual are also included. The loadings for the factors were achieved in separate analyses, where each item concentrates on one factor. Reliability in terms of ordinal  $\alpha$  was calculated with Equation 1 and ranged from .55 to .86 (median = .74) and loadings ranged from -.25 to .76. Negative loadings can be observed in 8 of the 160 TPT items, corresponding to the following scales: EST, ADA, ISO, DIS, DIN, and SIN.

Factor loadings for the three continuous EFA, root mean square, and factorial  $\alpha$  values are reported in Table 2. The loadings for these factors were also obtained in separate analyses, where each scale concentrates on its respective second-order factor. Reliability was also calculated with Equation 1 and values ranged from .78 to .89. All loading values were positive and ranged from .38 to .84.

Figure 1 shows the comparison between ordinal  $\alpha$ s and Cronbach's  $\alpha$ s for the scales as described in the TPT technical manual. Ordinal coefficients of all scales were significantly higher than their respective original continuous values ( $p < .001$ ), especially for the DAJ and DEP scales.

### Structural Analysis

In order to test how well the theoretical work personality model of the TPT (reported in the technical manual) fitted the data collected, we compare that model to a more parsimonious model with just one second-order latent variable. The theoretical work personality model of the TPT com-

**Table 2.** Factor loadings for TPT second order dimensions: EFA, RMSR, and  $\alpha$ 

Scale	EE	AM	RP
DAJ	.60		
ANS	.84		
DEP	.76		
EST	.78		
ACO	.71	.59	
TOL		.38	
ADA		.44	
CUL		.49	
ISO		.80	
INS		.84	
DIS			.65
EQU			.72
PRO			.82
DIN			.66
TES			.75
Mean	.74	.59	.72
RMSR	.001	.001	.001
$\alpha$	.89	.78	.87

prises 3 second-order factors with the following structure: EE includes DAJ, ANS, DEP, EST, and ACO; TOL, ADA, CUL, ISO, INS, and ACO constitute the AM factor; and DIN, PRO, EQU, TES, and DIS constitute the RP factor. Two CFAs with ML estimation were used. According to Schweizer's recommendations (Schweizer, 2010), the following goodness-of-fit indexes were calculated for the single factor model:  $\chi^2 = 3872.716$ ,  $df = 90$ , normed  $\chi^2 = 43.03$ , root mean square error of approximation (RMSEA) = .10 (.099 to .104), adjusted goodness-of-fit index (AGFI) = .83, comparative fit index (CFI) = .87, and standardized

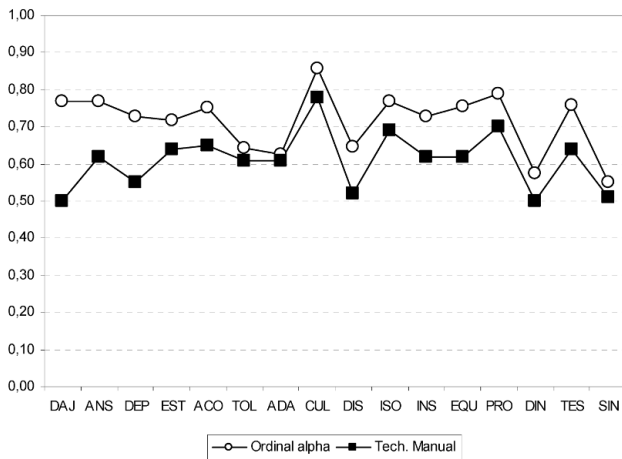

Figure 1. Ordinal  $\alpha$  vs. Cronbach's  $\alpha$  of the scales reported in the TPT's technical manual.

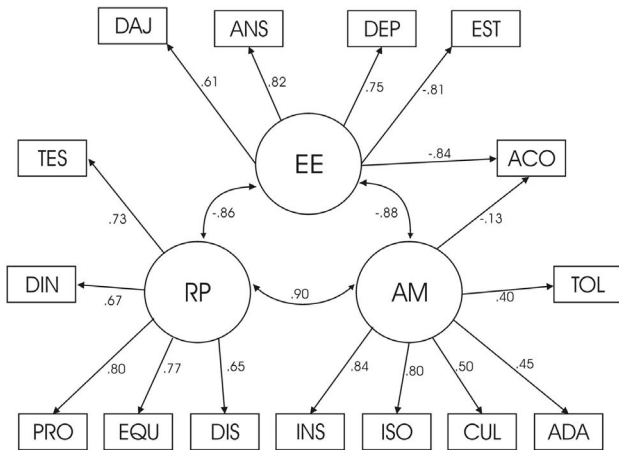

Figure 2. Standardized regression weights an CFA model of the theoretical TPT structure.

root mean square residual (SRMR) = .05; the three-factor model had the following goodness-of-fit indexes:  $\chi^2 = 2735.849$ ,  $df = 86$ , normed  $\chi^2 = 31.81$ , RMSEA = .08 (.084 to .090), AGFI = .89, CFI = .92, and SRMR = .05. These findings indicate a better fit of the theoretical model to empirical data than the more parsimonious model. Figure 2 presents the standardized regression weights and the structure of the theoretical model.

## Discussion

The aim of this study was to study the psychometric properties of the TPT and to provide updated, more accurate, and representative information about its properties, that is, its reliability and construct validity.

The first hypothesis that predicted an increase in the reliability of the TPT scales was confirmed according to the

data analyzed ( $p < .001$ ). Part of this increase is a result of the ordinal procedure used for its calculation, but it is widely argued that this is a more accurate reliability procedure, taking into account the Likert scale, than the equivalent procedure used and reported in the technical manual (Drewes, 2000; Elosúa & Zumbo, 2008; Lozano et al., 2008; Nunnally & Bernstein, 1994; Osburn, 2000; Ten Berge & Hofstee, 1999; Weng, 2004). These reliability results were expected; the TPT would hardly be one of the most commonly used tests in Spain (Muñiz & Fernandez-Hermida, 2010) if it lacked enough reliability to guarantee the required assessment quality. However, 5 of the 16 scales had reliabilities that could be improved according to the ordinal  $\alpha$  and loadings achieved. Two of them seems to be improvable with an extensive revision of the negative-loading items. That is the case for DIS and DIN. Moreover, TOL, ADA, and SIN could be indicating a comprehensive review of the overall item content.

Results related to the reliability of second-order dimensions were satisfactory; therefore, the TPT is a measuring tool with an acceptable (and improvable) accuracy of its scales and a good reliability of their second-order dimensions.

The second hypothesis tested was also confirmed by the empirical data. The TPT's psychological structure, consisting of three underlying second-order dimensions (Emotional Stability, Mental Openness and Responsibility), has been confirmed by the empirical data. According to the CFA results, the psychological content of the three dimensions can be better described. Emotional Stability is defined primarily by low levels of Anxiety, Depression, and Adjustment in the workplace, and as a good ability to manage stress and a good self-concept. This dimension has been shown to be an important trait of the work personality in other relevant tools developed in Spain (compeTEA, Arribas & Pereña, 2009) and Europe (BFQ; Caprara, Barbaranelli, & Borgogni, 1993; BIP; Hossiep & Paschen, 2008).

Mental Openness is a particularly interesting dimension because it is one of the Big Five model traits traditionally ascribed to the normal personality (McCrae & Costa, 1987, 1997) and seems to be important for the work personality as well. To be an open-minded person in the TPT parameters means to be tolerant and flexible, adaptive to changes, interested in other cultures, and with a high level of social intelligence and social integration in the company.

Responsibility is the factor most clearly related to performance at work (Salgado, 2003). Also included in other classic questionnaires such as NEO PI-R (Costa & McCrae, 1992) or SOSIA (Gordon, ECPA, 1990; Gordon, ECPA, & TEA Ediciones, 1997), Responsibility consists of a set of characteristics that define a "good worker": dynamism and activity, professional self-demanding, availability, tenacity, and constancy and teamwork.

A further interesting result was obtained. Most of the items of the TPT present high or moderate loadings on their respective scale, which influences the value of the reliability coefficient. However, eight of the items had a negative



loading on the EST, ADA, DIS, ISO, DIN, and SIN scales. It would be interesting to carry out future studies to examine and review the content of these items to increase the reliability of these scales. Additional study of the content of the scales that had lower loadings and reliabilities would also be interesting.

Despite the above encouraging results, there are some limitations to this study. First, because of the data collection system, the main purpose of the assessment was recruiting employees, but no data was available regarding the specific vacancy for which subjects were evaluated. Hence, the effect of this variable on the psychometric properties is unknown. Furthermore, it would have been interesting to have the ordinal data reliability from the technical manual. Finally, the TPT's theoretical model appropriately fits the empirical data for Spain. Future research could explore the usefulness of this model for other European countries.

## References

- Alonso-Arbiol, I., Balluerka, N., Shaver, P. R., & Gillath, O. (2008). Psychometric properties of the Spanish and American versions of the ECR Adult Attachment Questionnaire: A comparative study. *European Journal of Psychological Assessment, 24*, 9–13.
- Arribas, D., Corral, S., & Pereña, J. (2010). *CTC. TEA Clinical Questionnaire. Technical manual*. Madrid: TEA Ediciones.
- Arribas, D., & Pereña, J. (2009). *compeTEA. Technical manual*. Madrid: TEA Ediciones.
- Buela-Casal, G., Carretero-Dios, H., De los Santos-Roig, M., & Bermúdez, M. P. (2003). Psychometric properties of a Spanish adaptation of the Matching Familiar Figures Test (MFFT-20). *European Journal of Psychological Assessment, 19*, 151–159.
- Caprara, G. V., Barbaranelli, C., & Borgogni, L. (1993). *Big Five Questionnaire*. Florencia: O. S. Organizzazioni Speciali.
- Caprara, G. V., Barbaranelli, C., & Borgogni, L. (2005). *Big Five Questionnaire* (3rd ed.). Madrid: TEA Ediciones.
- Cattell, R. B., Cattell, A. K. S., & Cattell, H. E. P. (2005). *16PF-5. The Sixteen Personality Factor Questionnaire* (5th ed.). Madrid: TEA Ediciones.
- Child, D. (1990). *The essentials of factor analysis*. London: Cassell Educational Limited.
- Corral, S., Pereña, J., Pamos, A., & Seisdedos, N. (2002). *TPT. TEA Personality Test*. Madrid: TEA Ediciones.
- Cortina, J. M. (1993). What is Coefficient  $\alpha$ ? An examination of theory and applications. *Journal of Applied Psychology, 78*, 98–104.
- Costa, P. T., & McCrae, R. R. (1992). *Revised NEO Personality Inventory (NEO-PI-R) and NEO Five-Factor Inventory (NEO-FFI) professional manual*. Odessa, FL: Psychological Assessment Resources.
- Costa, P. T., & McCrae, R. R. (2008). *Revised NEO Personality Inventory (NEO-PI-R) and NEO Five-Factor Inventory (NEO-FFI) professional manual* (9th ed.). Madrid: TEA Ediciones.
- Cronbach, L. J. (1951). Coefficient  $\alpha$  and the internal structure of tests. *Psychometrika, 16*, 297–334.
- Drewes, D. W. (2000). Beyond the Spearman-Brown: A structural approach to maximal reliability. *Psychological Methods, 5*, 214–227.
- Elosúa, P., & Zumbo, B. D. (2008). Reliability coefficients for ordinal response scales. *Psicothema, 20*, 896–901.
- Feldt, L. S. (1980). A test of a hypothesis that Cronbach's  $\alpha$  reliability coefficient is the same for two tests. *Psychometrika, 45*, 99–105.
- Fernández-Seara, J. L., Seisdedos, N., & Mielgo, M. (2008). *CPS. Situational personality questionnaire. Technical manual*. Madrid: TEA Ediciones.
- García, O., Aluja, A., & García, L. (2004). Psychometric properties of Goldberg's 50 personality markers for the Big Five Model: A study in the Spanish language. *European Journal of Psychological Assessment, 20*, 310–319.
- Geisinger, K. F., Spies, R. A., Carlson, J. F., & Plake, B. S. (2007). *The seventeenth mental measurement yearbook*. Lincoln, NE: Buros Institute of Mental Measurements.
- Gomà-i-Freixanet, M., Valero, S., Punti, J., & Zuckerman, M. (2004). Psychometric properties of the Zuckerman-Kuhlman Personality Questionnaire in a Spanish sample. *European Journal of Psychological Assessment, 20*, 134–146.
- Gordon, L. V., & ECPA. (1990). *SOSIE, personality and motivation assessment*. Paris: Les Editions Du Centre de Psychologie Appliquée.
- Gordon, L. V., ECPA, & TEA Ediciones. (1997). *SOSIA. Competency management. Technical manual*. Madrid: TEA Ediciones.
- Gordon, L. V., ECPA, & TEA Ediciones. (2008). *SOSIA. Competency management. Technical manual*. Madrid: TEA Ediciones.
- Hathaway, S. R., & Mckinley, J. C. (2002). *MMPI-2. Minnesota Multiphasic Personality Inventory-2. Technical manual*. Madrid: TEA Ediciones.
- Hossiep, R., & Paschen, M. (2008). *BIP. The Bochum Inventory of Personality and Competencies. Technical manual*. Madrid: TEA Ediciones.
- Jöreskog, K. B. (1993). Testing structural equation models. In K. A. Bollen & J. S. Long (Eds.), *Testing structural equation models* (pp. 294–316). Newbury Park: Sage.
- Kostick, M. M. (1976). *PAPI. Perception and Preference Inventory. Technical manual*. London: Cubiks.
- Lenzenweger, M., Clarkin, J. F., Kernberg, O., & Foelsch, P. A. (2001). The Inventory of Personality Organization: Psychometric properties, factorial composition, and criterion relations with affect, aggressive dyscontrol, psychosis proneness, and self-domains in a nonclinical sample. *Psychological Assessment, 13*, 577–591.
- Les Editions du Centre de Psychologie Appliquée. (2005). *IPV. Personality Inventories for Sellers. Technical manual*. Madrid: TEA Ediciones.
- Lozano, L. M., García-Cueto, E., & Muñoz, J. (2008). Effect of the number of response categories on the reliability and validity of rating scales. *Methodology, 4*, 73–79.
- McCrae, R. R., & Costa, P. T. (1987). Validation of the five-factor model of personality across instruments and observers. *Journal of Personality and Social Psychology, 52*, 81–89.
- McCrae, R. R., & Costa, P. T. (1997). Personality trait structure as a human universal. *American Psychologist, 52*, 509–516.
- McDonald, R. P. (1999). *Factor analysis and related methods*. Hillsdale, NJ: Erlbaum.
- Méndez, F., Hidalgo, M., & Inglés, C. (2002). The Matson Eval-

- uation of Social Skills with Youngsters: Psychometric properties of the Spanish translation in the adolescent population. *European Journal of Psychological Assessment*, 18, 30–42.
- Millon, T. (2007). *MCMII-III. Millon Clinical Multiaxial Inventory – III. Technical manual*. Madrid: TEA Ediciones.
- Muñiz, J., & Fernandez-Hermida, J.R. (2010). The opinion of Spanish psychologists about the test use. *Papeles del Psicólogo*, 31(1), 108–121.
- Nunnally, J. C., & Bernstein, L.H. (1994). *Psychometric theory* (3th ed.). New York: McGraw-Hill.
- Osburn, H. G. (2000). Coefficient alpha and related internal consistency reliability coefficients. *Psychological Methods*, 5, 343–355.
- Penley, J. A., Wiebe, J., & Nwosu, A. (2003). Psychometric properties of the Spanish Beck Depression Inventory-II in a medical sample. *Psychological Assessment*, 15, 569–577.
- Rintala, D., Novy, D., Garza, H., Young, M., High, W.M., & Chiou-Tan, F. (2002). Psychometric properties of a Spanish-language version of the Community Integration Questionnaire (CIQ). *Rehabilitation Psychology*, 47, 144–164.
- Rodríguez-Fornells, A., Lorenzo-Seva, U., & Andrés-Pueyo, A. (2001). Psychometric properties of the Spanish adaptation of the Five Factor Personality Inventory. *European Journal of Psychological Assessment*, 17, 145–153.
- Ruipérez, M. A., Ibáñez, M. I., Lorente, E., Moro, M., & Ortet, G. (2001). Psychometric properties of the Spanish version of the BSI: Contributions to the relationship between personality and psychopathology. *European Journal of Psychological Assessment*, 17, 241–250.
- Rupp, A., Koh, K., & Zumbo, B.D. (2003, April). *What is the impact on exploratory factor analysis results of a polychoric correlation matrix from LISREL/PRELIS and EQS when some respondents are not able to follow the rating scale*. Paper presented at the annual meeting of the American Educational Research Association (AERA) in Chicago, Illinois.
- Salgado, J. F. (2003). Predicting job performance using FFM and non-FFM personality measures. *Journal of Occupational and Organizational Psychology*, 76, 323–346.
- Schweizer, K. (2010). Some guidelines concerning the modeling of traits and abilities in test construction. *European Journal of Psychological Assessment*, 26, 1–2.
- Seisdedos, N. (2002a). *MVR. Visual memory for faces. Technical manual*. Madrid: TEA Ediciones.
- Seisdedos, N. (2002b). *RP-30. Problem solving. Technical manual*. Madrid: TEA Ediciones.
- Seisdedos, N. (2004a). *Cambios. Cognitive flexibility test. Technical manual*. Madrid: TEA Ediciones.
- Seisdedos, N. (2004b). *Claves. Technical manual*. Madrid: TEA Ediciones.
- Seisdedos, N. (2008). *TISD. Selective interpretation of data test. Technical manual*. Madrid: TEA Ediciones.
- Ten Berge, J.M., & Hofstee, W.K. (1999). Coefficients  $\alpha$  and reliabilities of unrotated and rotated components. *Psychometrika*, 64, 83–89.
- Tsaousis, I., & Georgiades, S. (2009). Development and psychometric properties of the Greek Personality Adjective Checklist (GPAC). *European Journal of Psychological Assessment*, 25, 164–174.
- Tsaousis, I., & Kerpelis, P. (2004). The Traits Personality Questionnaire 5 (TPQue5): Psychometric properties of a shortened version of a Big Five Measure. *European Journal of Psychological Assessment*, 20, 180–191.
- Weng, L. J. (2004). Impact of the number of response categories and anchor labels on coefficient  $\alpha$  and test-retest reliability. *Educational and Psychological Measurement*, 64, 956–972.
- Zumbo, B.D., & Rupp, A. A. (2004). Responsible modeling of measurement data for appropriate inferences: Important advances in reliability and validity theory. In D. Kaplan (Ed.), *The SAGE handbook of quantitative methodology for the social sciences* (pp. 73–92). Thousand Oaks, CA: Sage.

David Arribas-Águila

Research and Development Department  
TEA Ediciones  
c/Fray Bernardino de Sahagún 24  
28036 Madrid  
Spain  
E-mail david.arribas@teaediciones.com